



MILLING REVOLUTION



Purifier
Michelangelo

DATA SHEET





Purifier

Michelangelo

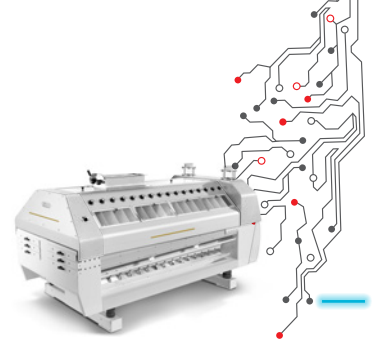

TECHNICAL FEATURES

It is equipped with:

- Subframe that includes discharging waste boxes;
- Sieving structure installed on elastic elements, with two triple superposed sieving lines;
- Two motovibrator give an alternating movement to the sieving structure;
- Feeding group adjustable for a uniform distribution of the product on the whole width of the sieve, directly connected to the aspiration, to avoid condensation;
- Aluminum sieves with sliding brushes on cursors with reversible movement for cleaning;
- Collection channels;
- Two independent aspiration chambers divided in sections with air regulation valves with micrometrical opening;
- Connection channels to the central aspiration;

The machine is completed of:

- aspiration hoods with adjustable butterfly valve;
- transparent plexiglas inlet;
- packing and brushes for sieves;
- sleeves;
- discharging boxes with three way valves.

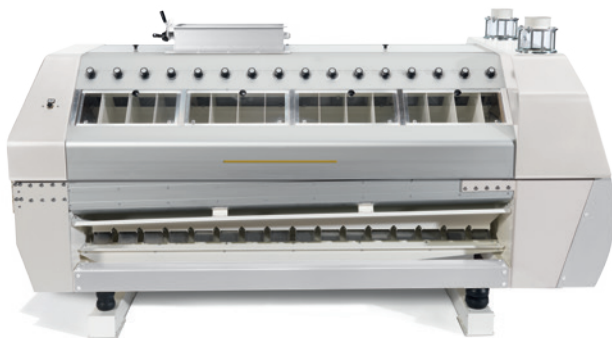



Purifier

Michelangelo

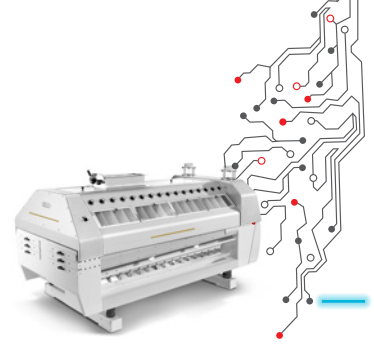

MAIN COMPONENTS

Small robust frames, in anodised aluminium and stainless steel AISI 304, with no welding: idea and solution patented by OMAS, the only one of its kind in the world.



Please note the clean corners, with no welding, guaranteeing maximum hygiene and sieving surfaces

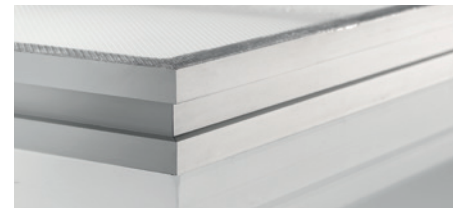

Flow can be regulated in the chambers, in three different points: by macro regulation in main aspiration, graduated micro-regulation of single sectors, by a simple knob.



Inner LED light, illuminating the internal sieves, facilitating regulation by the operator





Purifier

Michelangelo

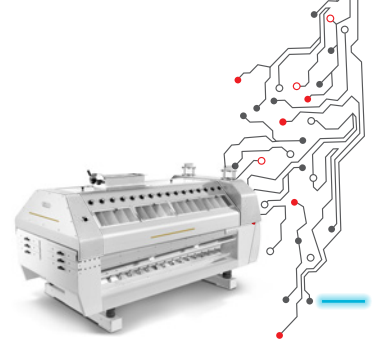

MAIN COMPONENTS

Sieves easy to extract, thanks to polyzen guides inside the machine: guaranteeing easy cleaning and extraction over time.



Anti-intrusion barriers have been mounted to protect products against any foreign bodies.





Purifier

Michelangelo

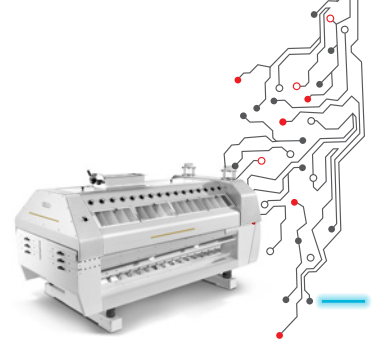

"MICHELANGELO" Mod. MI

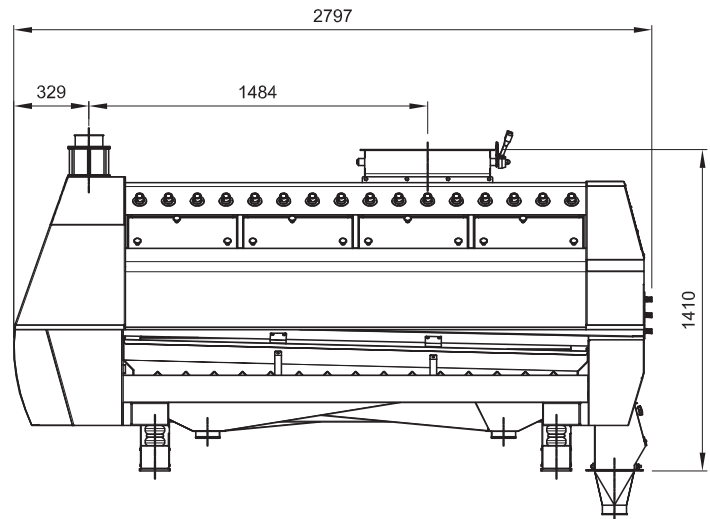
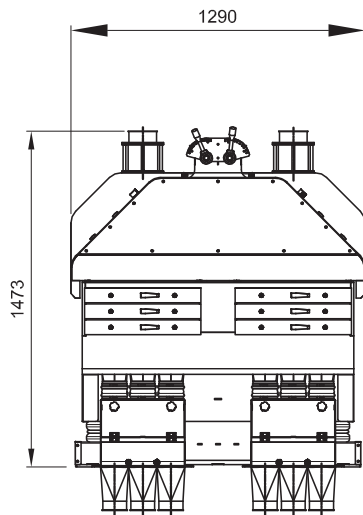

Mod. MI

Type	VIBROMOTOR		Hourly production	Weight	Sea packing volume
	TYPE	Power (N° x kW)	(t/h)	(kg)	(m³)
	ITALVIBRAS		4	2250	5,4
MI24-50	MVSI 06/780-MP-S08	2 x 0,4	5,5	3000	8,8

PERFORMANCE
EVOLUTION
IN THE ART
OF MILLING



MILLING REVOLUTION

Headquarter

Via Fornace II strada n° 1 - 35010 Arsego
S. Giorgio delle Pertiche, Padova - ITALY
Tel. +39 049 9330 297
Fax +39 049 9330 366
info@omasindustries.com
www.omasindustries.com



Sold and Serviced By:

Bratney Companies
3400-109th Street
Des Moines IA 50322 USA
Phone: 001 515 270 2417
info@bratney.com
www.bratney.com