

FISCHBEIN®

Model PILS 300™

Pinch Inner Liner Sealer

Fischbein Model PILS 300™

The Fischbein Model PILS 300™ Pinch Inner Liner Sealer features a continuous sealing process that sequentially seals the bag's inner liner and then folds and seals the top of the pre-glued pinch bag at speeds up to 75 linear feet per minute. The patented breakaway design eliminates costly downtime caused by bag jams while allowing easy cleaning and service of the hot air manifold and bag folder.



Shown with
optional conveyor

EVERYTHING IN BAGGING EQUIPMENT™



Fischbein® Model PILS 300™

Pinch Inner Liner Sealer

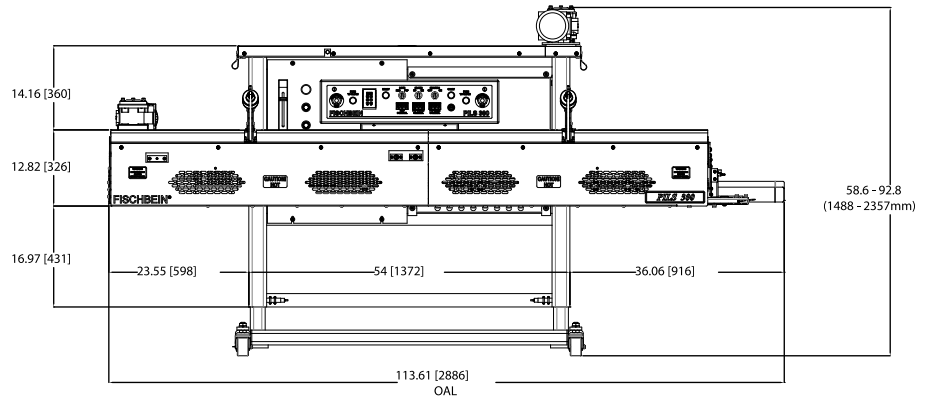
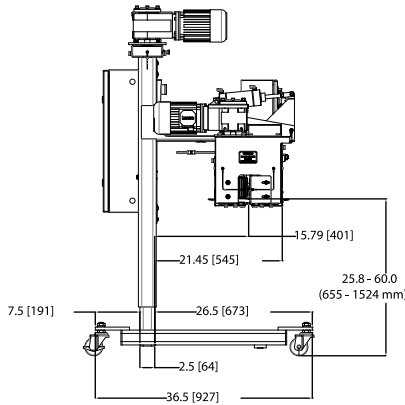

PILS 300

FEATURES

BAG TYPES

Multi-wall paper, pinch bags that have a preapplied hot-melt adhesive strip and a heat-sealable polyethylene or foil inner liners. Can also be used to seal standard pinch-style bags that do not have inner liners.

BREAKAWAY DESIGN LOW MAINTENANCE

The patented breakaway design eliminates costly downtime caused by bag jams while allowing easy cleaning and service of the hot-air manifold and bag folder.

USER FRIENDLY CONTROLS

Safe and easy to use control panel with digital temperature display, key pad for variable speed control, and dual emergency stop buttons.

STANDARD

Over-temperature sensor auto shutdown.

Motorized adjustable seal height to reduce change-over time.

Bag top air scrubber removes product debris from seal area.

OPTIONS

- Left to right operation
- Reverse fold - rear direction
- Extended infeed for automation applications
- Additional motor starter and contactor for conveyor
- CR Plus 2 part corrosion resistant powder coat finish
- Stainless steel NEMA 4 X washdown version
- 575 VAC

SPECIFICATIONS

- Dimensions: L 114 in (290 cm), D 37 in (94 cm), H 92 in (234 cm)
- Speed: Up to 75 linear feet per minute
- Electric (NEMA 12): 230/380/460V-3PH-60Hz, 24 VAC
- Air: 10 cfm @ 80-100 PSI

BAGS

- Bag Types: Multi-wall paper gusseted open
- Gussets: Any size including flat bags
- Mouth pinch bags with heat sealable inner liner
- Free Bag Top: Minimum 6 in (15.2 cm)

APPLICATIONS

- Bakery Mixes
- Minerals
- Pet Food
- Feed Additives
- Fertilizers
- Agricultural Seed
- Chemicals
- Cat Litter
- Powdered Dairy Products
- Food

704-871-1159

**HAMER
FISCHBEIN®**

A DURAVANT COMPANY

Specifications are subject to change without notice.

