

FISCHBEIN®

Model 500 THPS™

Synchronous Tape Sewing System

Fischbein Model 500 THPS™



The Fischbein Model 500 THPS™ is a synchronous tape sewing system that closes multi-wall paper and laminated woven polypropylene open mouth bags at speeds up to 75 linear feet per minute. Automatic synchronization of the sewing head, in-feed system and bag conveyor creates the perfect sew tape closure. Synchronous, variable-speed drive technology allows the 500 THPS™ to instantly change sewing speeds with the push of a button.

EVERYTHING IN BAGGING EQUIPMENT™



Fischbein® Model 500 THPS™

Synchronous Tape Sewing System

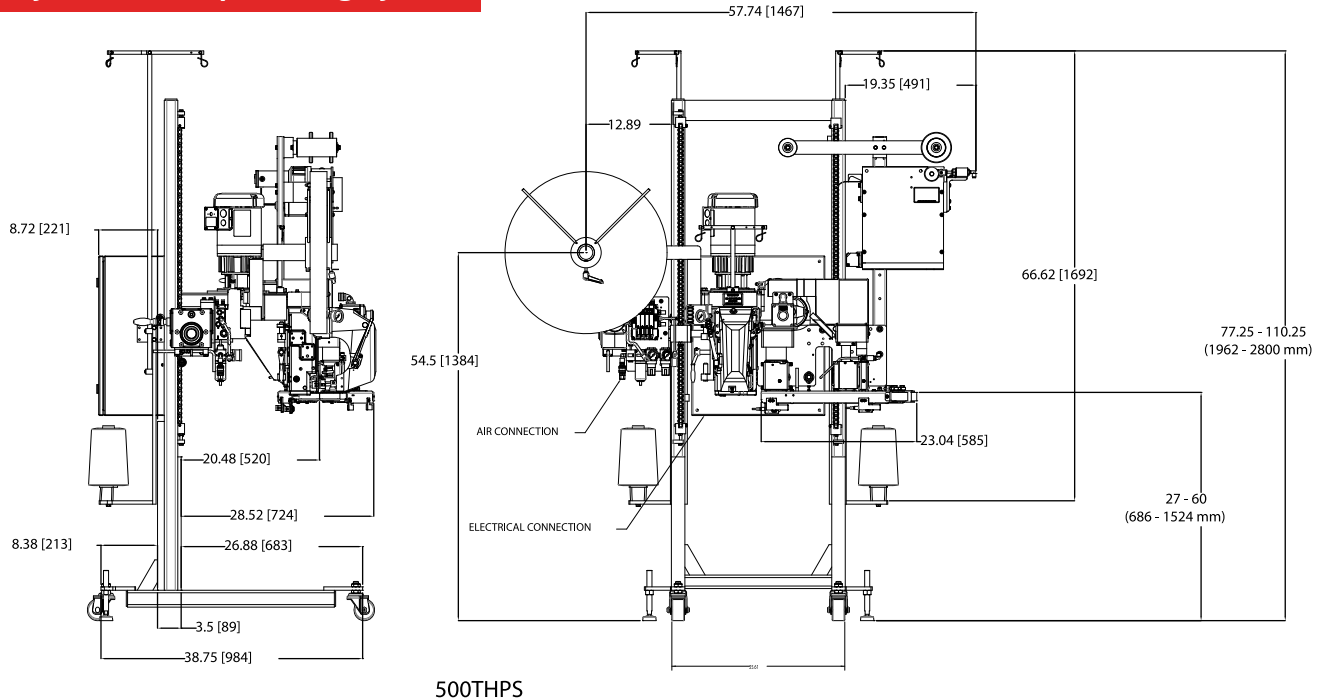

500THPS

FEATURES

BAG TYPES

Closes a variety of bags including flat and gusseted multi-wall paper, and woven polypropylene bags.

EMPRESS 201 SEWING HEAD

With its self-lubricating system, the Empress 201 delivers trouble-free smooth performance with low vibration. Operating speed is adjustable up to 75 linear feet per minute.

BAG TOP TRIMMER

Specifically designed with quick change, long life blades that ensure thousands of hours of trouble-free operation.

SPEED SETTINGS

Head and infeed speeds are synchronized via variable frequency drives. A timing belt between the sewing head and motor ensures consistent, drift-free control.

COMES STANDARD WITH:

Heavy duty clutch and 3HP motor, powered crepe tape feed system, quick change circular trimming knives, high performance tape clipper and tape, thread and oil sensor package.

OPTIONS

- Tagger infeed
- Tape contact coder (P2375)
- Motor starter and contactor for conveyor
- 575 VAC

SPECIFICATIONS

- Dimensions: L 58 in (147 cm), D 41 in (104 cm), H 78 in (198 cm)
- Speed: Up to 75 linear feet per minute
- Electric (NEMA 12): 230/380/460 VAC, 3 PH, 50/60 Hz
- Air: 15 cfm @ 90 PSI

BAGS

- Bag Types: Multi-wall paper and laminated woven polypropylene open mouth bags
- Bag Thickness: Maximum 12 mils
- Free Bag Top: Minimum 6 in (15.2 cm)

APPLICATIONS

- Fertilizers/Minerals
- Chemicals
- Cat Litter
- Pet Food
- Feed Additives
- Agricultural Seed
- Bakery Mixes
- Powdered Dairy Products

704-871-1159

**HAMER
FISCHBEIN®**

A DURAVANT COMPANY

Specifications are subject to change without notice.

